

HEAVY DUTY TAPERED (fits 3/8" diameter elements)

Style T (Tapered)

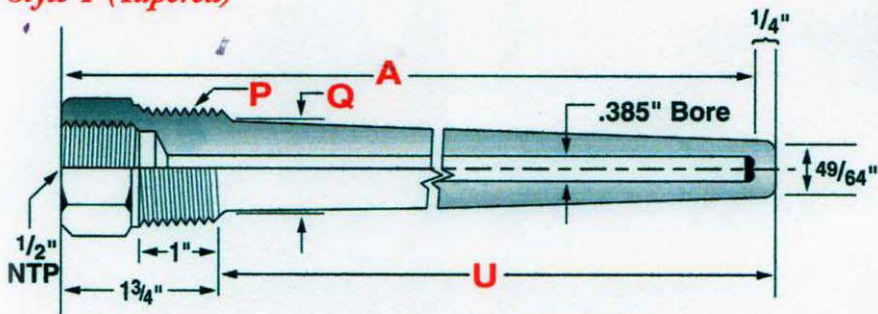

Style H (Extended Lagging)

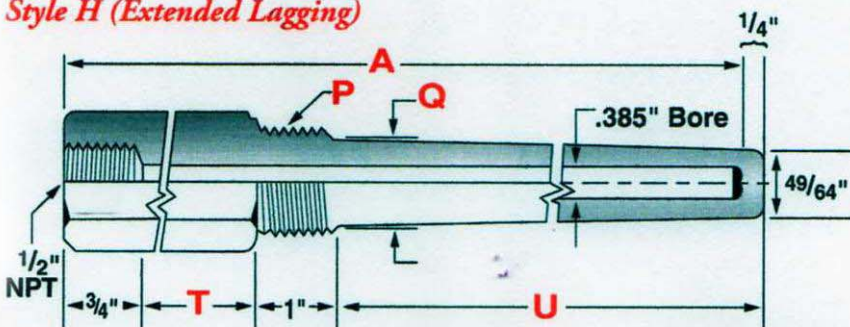

Tapered Shank

P Ext. Thread	Order Code	A Length	U Insertion	Q Shank Dia.
3/4" NPT	102T	4	2 1/2	7/8
		6	4 1/2	7/8
		9	7 1/2	7/8
		12	10 1/2	7/8
		15	13 1/2	7/8
1" NPT	108T	4	2 1/2	1 1/16
		6	4 1/2	1 1/16
		9	7 1/2	1 1/16
		12	10 1/2	1 1/16
		15	13 1/2	1 1/16
18	16 1/2	1 1/16		

Tapered Shank (Extended Lagging)

P Ext. Thread	Order Code	A Length	U Insertion	Q Shank Dia.	T
3/4" NPT	H102T	Deter- mined by T value	2 1/2	7/8	S P E C I F Y
			4 1/2	7/8	
			7 1/2	7/8	
			10 1/2	7/8	
			13 1/2	7/8	
1" NPT	H108T	Deter- mined by T value	2 1/2	1 1/16	S P E C I F Y
			4 1/2	1 1/16	
			7 1/2	1 1/16	
			10 1/2	1 1/16	
			13 1/2	1 1/16	
16 1/2	1 1/16				

Standard Insertion Lengths (U) shown... ALL other sizes available.