

FLANGED THERMOWELLS

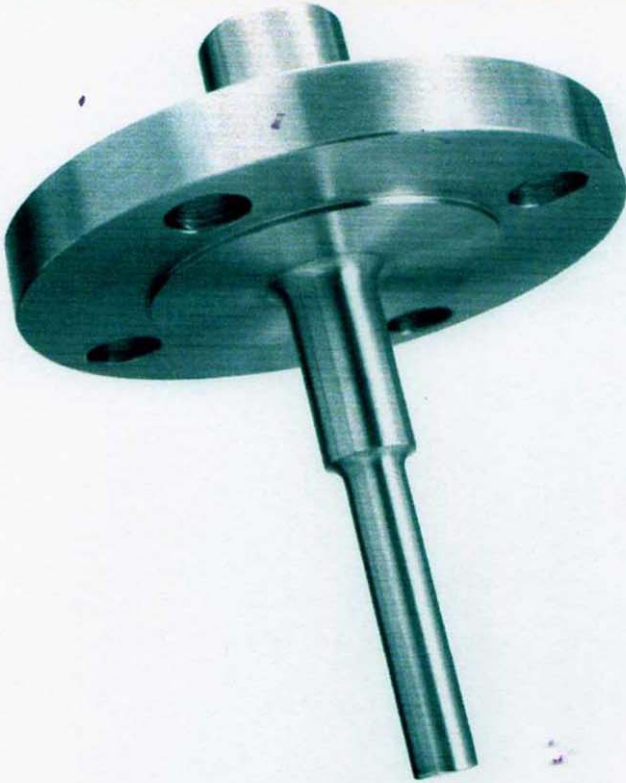

Style ST (Stepped)

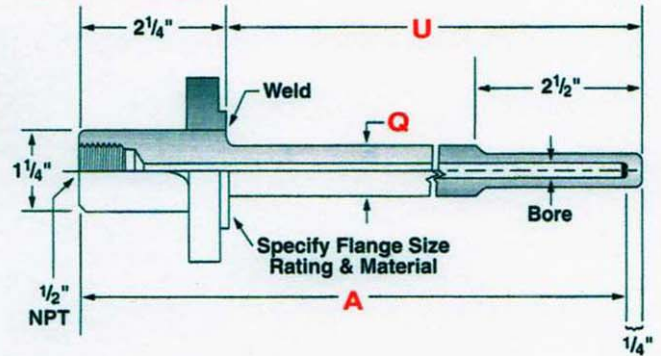

Style S (Straight)

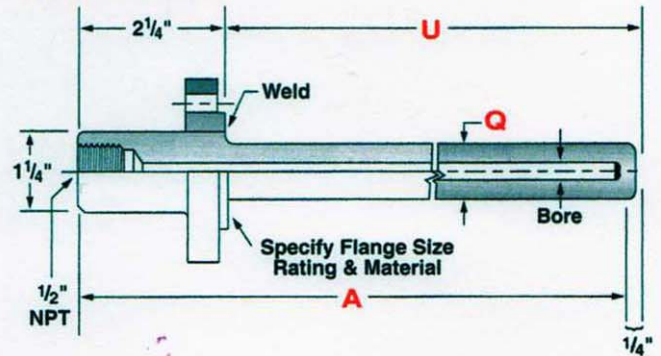

Style T (Tapered)

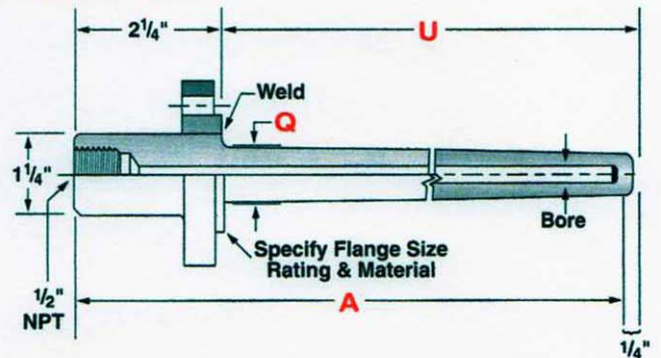

Order Code	Shank Diameter Q	Bore	Style
703ST	3/4"	.260	Stepped
702ST	7/8"	.385	Stepped
703S	3/4"	.260	Straight
702S	7/8"	.385	Straight
703T	7/8"	.260	Tapered
702T	1 1/16"	.385	Tapered

Flange Code

Size	Rating	Design
1"	150#	RF = RAISED FACE
1 1/2"	300#	
2"	600#	FF = FLAT FACE
2 1/2"	900#	
3"	1500#	RTJ = RING JOINT